

SAW BASED TRANSMITTER DESIGN NOTES

By: Jie Nie, 08/20/2003

The major benefit of a SAW resonator results in a low cost SRD transmitter and local oscillator. For example SAW resonator is widely used in the RKE transmitter. In this type of application, most customers want a compact size and a coin cell battery. The way to get the best performance under there condition is very difficult for most engineers. In order to help our customers to design-in with our SAW resonator, here we have some suggested schematic with components value and PCB layout for their reference.

1. SAW Based Transmitter for 300 – 500 MHz

a). RFM SAW Resonator Part Number and Frequency

Freq. (MHz)	303.825	315	418	433.92
Part No.	RO2104A, D, E	RO2073A, D, E	RO2103A	RO2101A, D, E
Applied Area	AU, Asia, US	US, Asia	US, UK	AU, EU, India

b) Transmitter Schematic

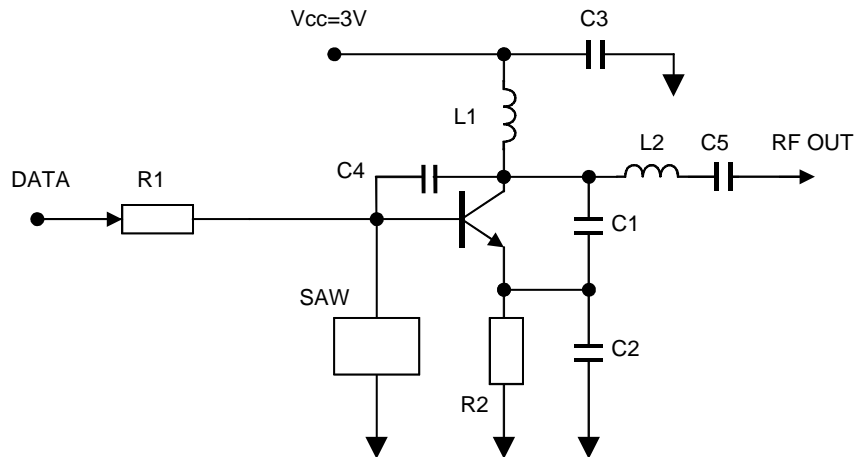

d) Components Value

Transistor: BFS-17A,
MMBTH-10LT1, NE68030 etc.

C1: 1 – 5.1 pF

C2: 8.2 – 18 pF

C3: 470pF

C4: 1 pF

L1: 18 – 33 nH

R1: Adjust for output power

R2: 100 Ohm

L2 and C5 impedance match option..

Figure 1

2. SAW Based Transmitter for 800 – 1000 MH

a). RFM SAW Resonator Part Number and Frequency

Freq. (MHz)	868.35	916.5
Part No.	RO2164A, D, E	RO2144A, D, E
Applied Area	AU, EU	US,

b) Transmitter Schematic

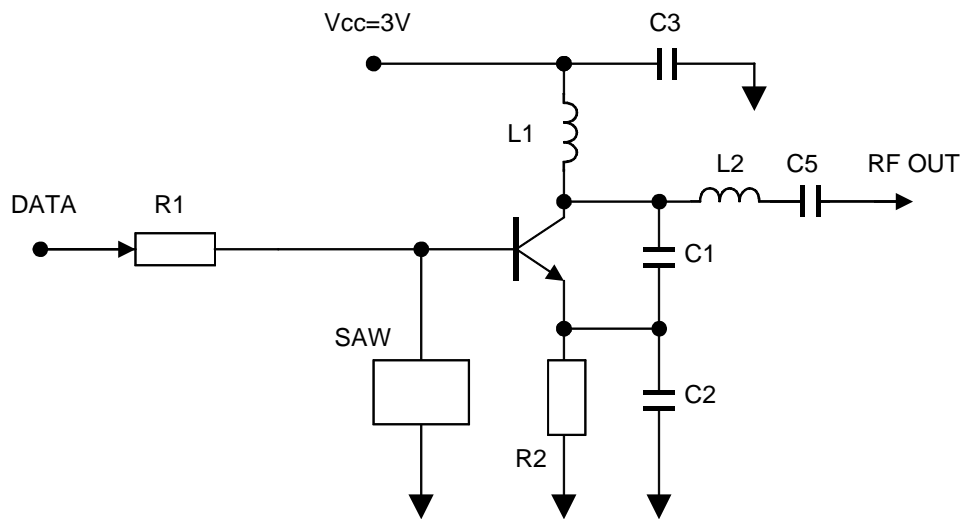

L2 and C5 impedance match option..

Figure 2

d) Components Value

Transistor: MMBR-901, NE68030 etc.

C1: 1 – 2.2 pF

C2: 5.1 – 8.2 pF

C3: 220pF

L1: 3.9 – 6.8 nH

R1: Adjust for output power

R2: 100 Ohm

3. PCB Layout

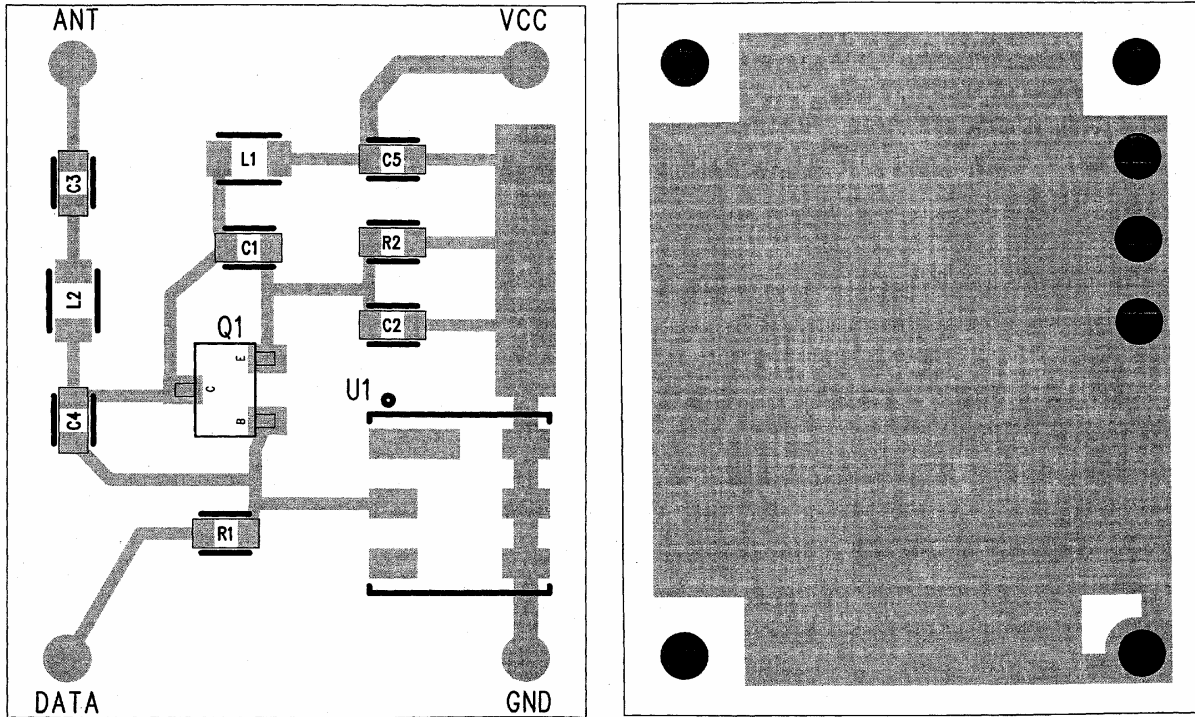

Dimensions: 0.5" x 0.6"